

Mounting a lock bracket on a bike is not an easy task. Think about it: you have to position a heavy object (the lock) in a functionally safe and secure fashion onto a moving object (the bike) using a bracket that is not permanently affixed to the bike.

There are two challenges to overcome. First, you have to determine where to mount the lock bracket so that the lock will be out of the way while you pedal, yet easily accessible when you need it. Then, you actually have to install the lock bracket properly so that the lock and bracket will not shift when you hit bumps in the road.

CHOOSING BRACKET POSITION

Determining where to mount the lock is perhaps the more difficult of the two tasks. To determine where to place the mounting bracket, place the lock inside the mounting bracket and choose a tube on the bike that will allow the lock to mount easily. Modern frame geometries, larger locks, and brake/shifter cables running along the frame all complicate the choice. Note that you will need some extra space for inserting the key in the lock once it is mounted. Each bike presents unique problems, but there are a few standard solutions:

Seat post

- a. PRO: Does not interfere with water bottles or cables
- b. CON: May interfere with thighs during pedal stroke
- c. CON: may not work with bikes equipped with suspension seatposts or smaller frames that have low seatheight

Top tube, in line

- a. PRO: Lock and bracket out of the way for pedaling
- b. PRO: Won't interfere with most cable routings
- c. CON: May prevent using waterbottle cages on down tube

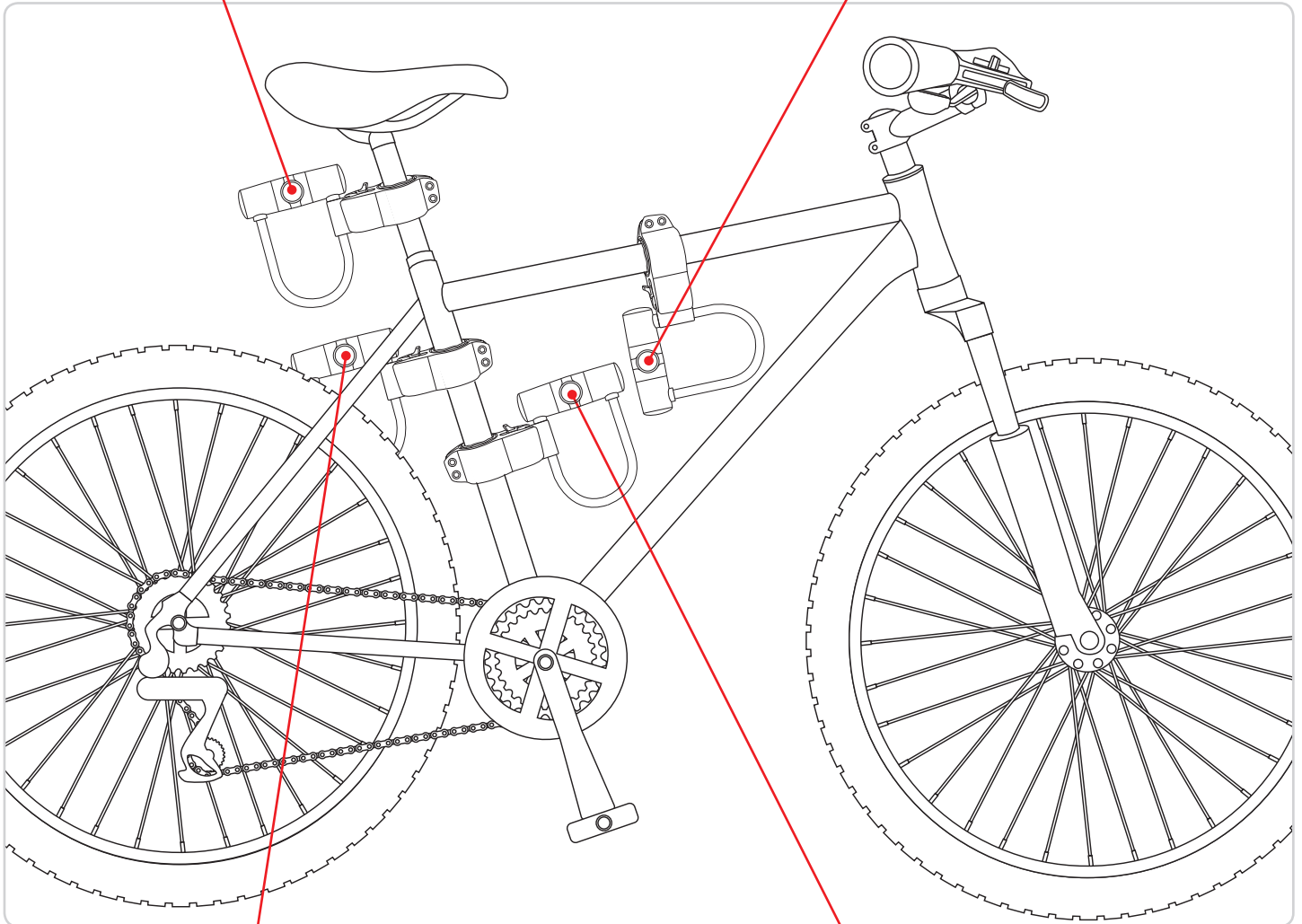

Seat tube, rear triangle non-drive side

- a. PRO: Works on most frames
- b. CON: May interfere with crank motion or rear brake
- c. CON: May interfere with pedal stroke
- d. CON: Not optimal for top-pull front derailleurs
- e. CON: Lock may bounce around and scratch frame

Seat tube, in line

- a. PRO: Lock and bracket out of the way for pedaling
- b. CON: Won't work on most compact frames
- c. CON: Prevents using one, or possibly two waterbottle cages
- d. CON: If the bracket is not installed properly, the lock may swing because it is not supported by any other part of the bike

Lock brackets have two main parts: the lock bracket itself, and the mounting spline that is attached to the lock. Lock brackets are made up of one or two pieces that clamp around a tube. Aside from the difficulties discussed of how the lock bracket may interfere with the bike's proper functioning, other problems may arise:

- The tube is too large or oddly shaped. This is why we offer several mounting suggestions. If no tubes on the frame work, the bracket will mount on all standard seatposts.
- The bracket is not affixed tightly enough: Because locks are heavy, brackets will tend to rotate and slip. This presents an inconvenience and safety concern. To prevent this from happening, you have to tighten down the bracket (not too tight, though, as you can crush a tube or strip a bolt). It also helps to increase the friction between the bracket and tube. Rubber spacers are a must, not only to increase friction, but also to protect the frame.

MOUNTING THE BRACKET

Place rubber shim on the bike tube.

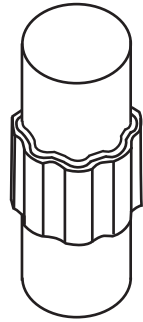

Attach bracket body to bike frame.

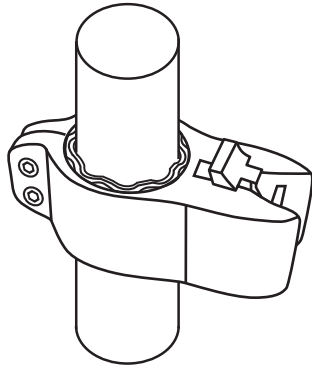

Adjust for proper orientation of bracket body on bike tube.

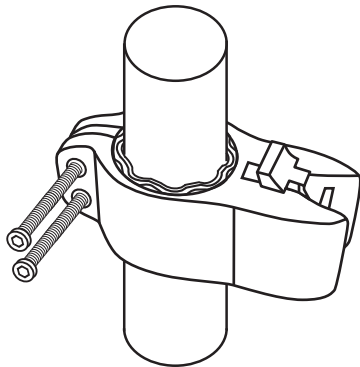

Tighten adjustment bolts.

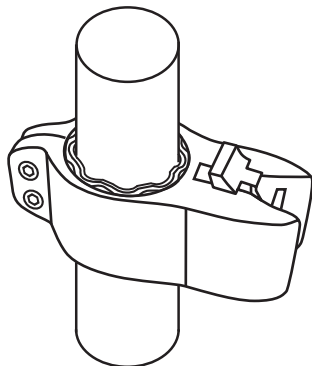

MOUNTING SPLINE ADJUSTMENT

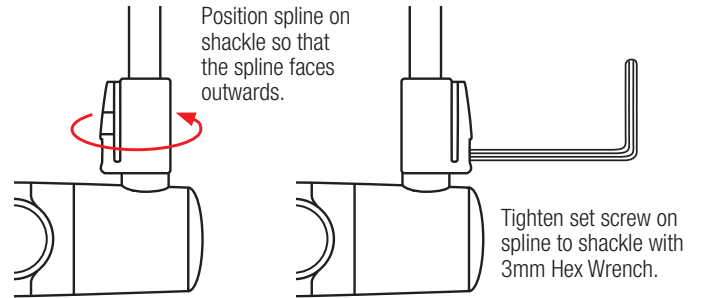

SECURING/REMOVING LOCK FROM BRACKET

